

F120 OPTIAL GYRO SPECIFICATION





Descriptions

This product is an inertial angular rate sensor based on the principle of Sagnac, which is used to measure the angular rate motion of the carrier around the sensitive axis of the product. This product with fiber ring for angular rate sensing unit, based on the closed-loop detection circuit, the phase difference caused by sensitive angular rate of optical fiber ring, change into intensity signal by interference , detecting circuit change the intensity signal into voltage signal, and the signal is detected through the modulation and demodulation,Then feedback signal back to the optical path, to realize the closed-loop control.

This product is an inertial sensor composed of optical system and corresponding power supply and data processing circuit, which can provide incremental information of single axis angle.

This product is mainly used in inertial measurement system of high precision inertial navigation system and positioning & orientation system.

Features

- All-fiber design -long lifespan, small package size, high stability and more resistance to interference.
- Integrated fiber polarizer -minimum insertion loss and high extinction ratio, offering more resistance to temperature and mechanical shock, as well as intense vibration.
- Reliable compact package -operationally robust for all kinds of environments, ideal for a wide of applications in both civilian and military areas.
- QuickLaunch technology -minium activation time with no external calibration required.
- Optimal wavelength -improves the sensibility by 50% with the same structure, size and cost.
- Noise isolation and compression -significantly reduces the angle random walk.
- SelfTrack technology -improves the gyro dynamic range

Applications

- UAV/AUV/Helicopter
- Tactical nuclear weapons
- Aeronautics and astronautics
- Integrated navigation system
- inertial platform stabilizing
- Vehicle navigation



Components inside

- a) Optical components: Fiber optic ring、Y waveguide、Coupler、ASE source of light、PIN-FET detector;
- b) The source of light drive circuit, Detection and signal control circuit board;
- c) Fiber optic ring frame、Outcover、Topcover、Bottom plate;

Performance Characteristics

Project	unit	F120A	F120B	F120C	F120D
Measuring range	°/s	-500~+500	-500~+500	-500~+500	-500~+500
Zero offset stability	°/h	≤ 0.003	≤ 0.008	≤ 0.01	≤ 0.03
Zero bias repeatability	°/h	≤0.003	≤ 0.008	≤0.01	≤0.03
Random walk coefficient	°/√h	≤0.0004	≤0.0008	≤0.001	≤0.003
Scale factorNonlinear	ppm	≤5	≤10	≤20	≤ 30
Scale factorRepeatability	ppm	≤ 5	≤10	≤20	≤ 30
Scale factorAsymmetry	ppm	≤5	≤10	≤20	≤30
Start Time	s	≤1			
bandwidth	Hz	> 100			
power supply	V	-5,+5			
power	W	≤6			
Operating temperature	°C	-40~+65			
storage temperature	°C	-45~+85			
vibration	Hz, g2/Hz	20~2000,0.06			
Shock	g, ms	30,11			
Data refresh rate	Hz	200~500			
Baud rate	bps	115200~921600			
outputmethod	/	Broadcast (default) / triggered (custom)			
Interface level	/	RS-422			
Connector	/	J30J-15TJL			
shape size	mm	Φ120×39.5			

Environment requirement

Power supply	+5V	-5V
The fluctuation of voltage	4.75V~5.25V	-4.75V~-5.25V
Rated ripple voltage	20mV	20mV
Power consumption	1.5A	0.6A

Interface definition

Pin No.	Signal name	Description
1, 7, 12, 17	+5V	Gyro power supply (note: light source power supply on PCB and power supply on mainboard is short-circuiting)
6, 13, 14, 16	±5V GND	
4, 15	-5V	
2	NC	Alternate TTL level signal external
3, 5	NC	
8, 18	T+	RS422 Send
9, 19	T-	
10, 20	R+	RS422 Receive (differential synchronous signal)
11, 21	R-	
F98 Type gyro connector model:		
Socket	J30-21TJ (LN6.480.025, L=300mm)-Q/Ln.J6-69A -2003	
Plug	J30-21ZK	

Noted:Anti-static electricity measure should be taken whenever touch and connect the pin of the product.

Dimensions

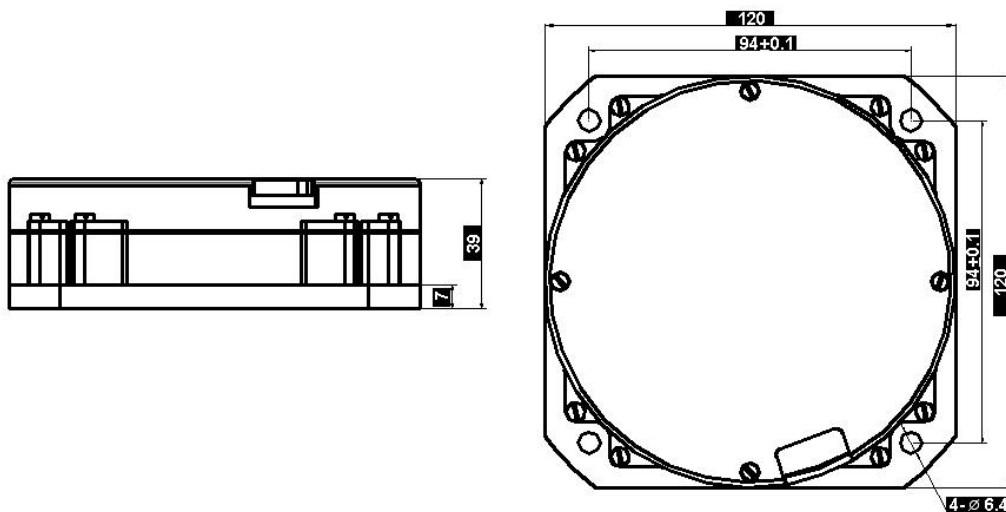

©COPYRIGHT 2013.FIREPOWER TECHNOLOGY.

Gyro communication protocol

- 1) input synchronous square wave: gyro receive external 400Hz square wave through RS422, synchronization time is positive pulse falling edge synchronization
- 2) Canbus type: RS422
- 3) Baudrate:460,800 bps
- 4)Data refresh rate: 400Hz
- 5) Interface definition: see table below:

	Data frame name	Gyro output data	Version:A
	Frame description	Speed output value	
content	Type	Asynchronous serial data	
	Source	Optical fiber gyro	
	Standard	RS422; baud rate: 460,800 bit/s; 1 start bit, 8 bit data , no parity bit,1 stop bit	
	Refresh rate	2.5ms	
Byte No.	Signal name	Signal description	
1	Package header	0xEB	
2		0x90	
3	Gyor speed	4 bytes 32 bit integer with signal, byte 3 is the lowest 8 bit, byte 6 is the highest 4 8 bit. Scale factor is 1	
4			
5			
6			
7-10	Retain	Fill in 00	
11-14	Retain	Fill in 00	
15	Temperature/status	Temperature information	
16		Status: 0~3; update period: 2.5ms send by turns	
17	15,16 bytes data description	Status 0: gyro temp.; status 1: retain; status 2: retain; status 3:working status	
18	Cycle count	Add 1 to the value of each package data, after reach 255, the value of next package data is 0;	
19	Check sum	Accumulate from byte 3 to 8, take low 8 bytes as	

Note on installation

Please avoid impact during installation, and no machining work on its surface is allowed.

Check before installation:

- a) check if there is physical damage on the product
- b) Under ordinary temperature, use insulation resistance meter test the insulation resistance between all pins of output interface and its shell, should $\geq 60M\Omega$
- c) Test all technical parameters when necessary
- d) The flatness of installation surface against the product should be better than 0.05mm
- e) When installation, 0.2~0.5mm layer of heat conducting silica gel is required to be coated under the bottom of the product
- f) Check if all screws are fixed steadily after installation

Product maintenance

- a) Before loading into the carrier, it is required to electrify the product one time at least every year, and the power one time is 3600s, and the electrical parameters of the product are not required to be detected when the power is switched on;
- b) After the product is loaded into the carrier, it is required to electrify the product one time at least every year, and the power one time is 3600s, and the electrical parameters of the product are not required to be detected when the power is switched on;
- c) Products should be re calibrated every 8 years.

Common fault phenomena and troubleshooting methods

1.This product is in the state of full seal, and can not be repaired on the spot after any fault occurs at the user's sides, and needs to be returned to the product manufacturer for repair.

2.Here below are only a list of possible failures of the non - product itself, see table 5. If there are other technical problems occurs during using of products, please the user to contact the products manufacturer.

(Common fault and resolvent)

Item	Fault phenomena	Reason analysis	Resolvent
1	Product electrify, +5V、-5V ,the current indicator of the ammeter is basically 0	No power supply or current supply is too small for the product	Check the power supply and power supply circuit to restore the power supply
2	Product electrify, +5V、-5Vthe ammeter current is normal, but the computer acquisition program doesn't work	The acquisition system of test equipment unusual	Check the connection cable, equipment power supply situation
		Software program conflict	Restart the test computer
3	Product electrify, +5V、-5V the current indicator of the ammeter is abnormal	A short circuit may occur inside the test equipment	Inspection and test equipment

Requirements for transportation and storage of products

5.1 Transportation notice

- a) Place the product according to the direction shown in the packing box;
- b) When the temperature range is $-40^{\circ}\text{C} \sim +65^{\circ}\text{C}$, it is allowed to be transported by road, railway, air and water transportation;
- c) Ensure that the packing box is fastened to the carrier without moving during shipment.

5.2 Storage notice

- a) The products placed in the packing box should be stored in an air conditioned warehouse under standard atmospheric pressure, environmental temperature is $15^{\circ}\text{C} \sim 35^{\circ}\text{C}$;
- b) The storage period of the product is 15 years .

Unpacking and inspection

6.1 Unpacking inspection

- a) Check the appearance of the packing box for collision and other physical damage;
- b) Static electricity protection should be carried out when taking out the product .

6.2 Inspection of supporting delivery documents

- a) Product qualification certificate;
- b) F98 Acceptance report of closed loop fiber optic gyroscope;
- c) F98 Maintenance instructions for closed-loop fiber optic gyroscope (1pcs per batch) .